

# ACTIVE MASS DAMPER



## Bench-scale smart structure

The Quanser Active Mass Damper (AMD) is a bench-scale model of a tall building equipped with an active damper. It is ideal for studying the dynamic response of tall structures to high winds, seismic ground effects, and other disturbances, and for investigating control techniques to actively dampen the deflection of structures.

The damper consists of a motorized linear cart instrumented with an encoder measuring the cart's displacement. Additionally, the structure is instrumented to measure floor acceleration.

The Quanser Active Mass Damper is available in three different configurations: one-floor AMD, two-floor AMD with a single active cart, and two-floor AMD with two active carts. The structures can be mounted on the Quanser Shake Table I-40 (one-floor AMD) or Shake Table II (one- or two-floor AMD).

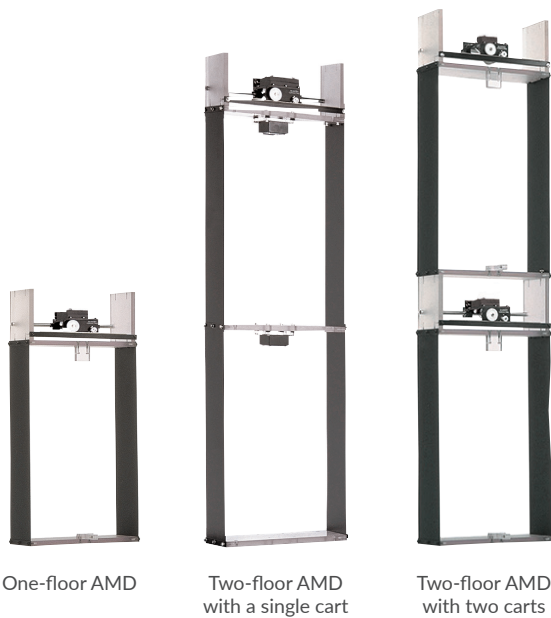
### Features

**Accurate**  
Precise cart position measurements using high-resolution optical encoders



**Customizable**  
Variable cart load mass



**Open**  
Open architecture design with fully documented system models and parameters



**Flexible**  
Flexible operation and control design using MATLAB®/ Simulink® and QUARC™

### Workstation Components

AMD structure	One-floor Active Mass Damper Two-floor Active Mass Damper with a single cart or two carts
Data acquisition device	Quanser Q2-USB (Q8-USB when used with Shake Table II)
Amplifier	Quanser VoltPAQ-X1 (one-floor AMD) Quanser VoltPAQ-X2 (two-floor AMD)
Control design environment	QUARC Software for Simulink - Essentials license

## Product Details

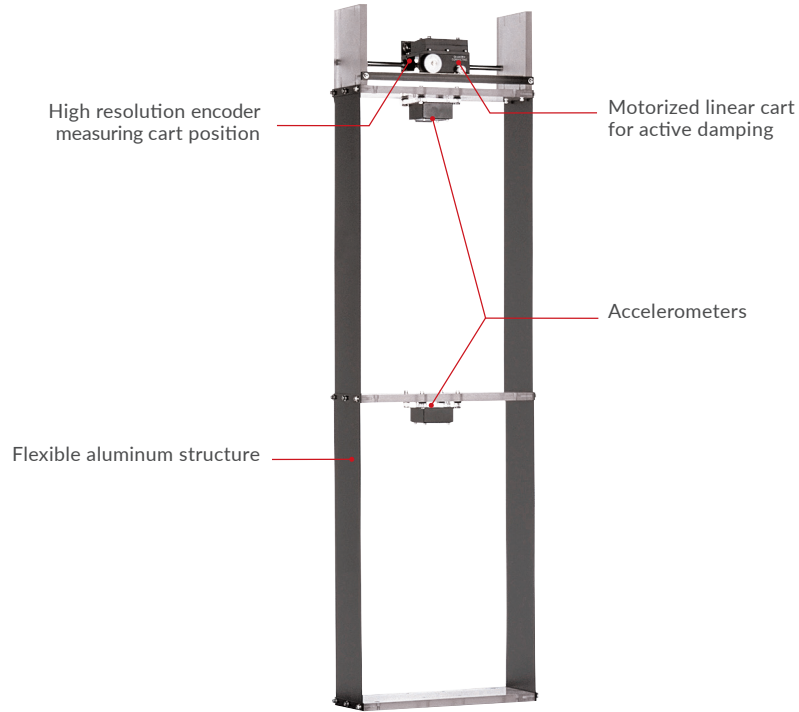

## Device Specifications

Flexible structure height (each floor)	50 cm
Cart rack height	13 cm
Flexible structure natural frequency	1.57 Hz
1 <sup>st</sup> floor flexible structure linear stiffness (relative to the ground)	173 N/m
2 <sup>nd</sup> floor flexible structure linear stiffness (relative to the 1 <sup>st</sup> floor)	173 N/m
Cart travel	±9.5 cm
Cart encoder resolution	4096 count/rev
Accelerometer sensitivity	1.0 g/V

	One-floor AMD	Two-floor AMD with a single cart	Two-floor AMD with two carts
Dimensions (L x W x H)	32 x 11 x 63 cm	32 x 11 x 113 cm	32 x 11 x 126 cm
Total mass	2.83 kg	4.33 kg	5.65 kg

### About Quanser:

For 30 years, Quanser has been the world leader in education and research for real-time control design and implementation. We specialize in outfitting engineering control laboratories to help universities captivate the brightest minds, motivate them to success and produce graduates with industry-relevant skills. Universities worldwide implement Quanser's open architecture control solutions, industry-relevant curriculum and cutting-edge work stations to teach Introductory, Intermediate or Advanced controls to students in Electrical, Mechanical, Mechatronics, Robotics, Aerospace, Civil, and various other engineering disciplines.

Products and/or services pictured and referred to herein and their accompanying specifications may be subject to change without notice. Products and/or services mentioned herein are trademarks or registered trademarks of Quanser Inc. and/or its affiliates. ©2019 Quanser Inc. All rights reserved.